



Application – Assisted Living Tech Works Solution - Voice-Call

General Description -

Assisted Living properties all face the challenge of providing quality care with a limited staff that typically experiences a high rate of turnover. For these reasons a communication system must be easy to operate and flexible enough to meet the specific needs of each and every facility. Using cordless telephones, staff members are free to move about the property and attend to other duties. A call for assistance rings the phone and the Caller ID notifies staff who is calling and their location. Assisting the resident is as easy as answering the phone and who needs training for that?

Basic system components:

Product	Purpose or Function
	User Interface Devices:
2590-TC	Telephone Console with Caller ID
2590-TW	Cordless Telephone with Caller ID
2051	Patient speaker station w/ jack for call cord, speaker, cancel button and confirmation LED
2052	Emergency pull station w/ speaker, cancel button and confirmation LED
2055	Speaker station with push-for-help button, speaker, and confirmation LED
	System Control Devices:
2528	High Power Intercom Amplifier supports up to eight 25-volt industry standard speakers
PS1260	Power Supply
	System Interface Devices:
2590	Telephone interface module supports any consumer grade corded or cordless telephone w/ CID

Benefits of using Tech Works –

- Distributed processing allows for easy installation and configuration of each calling station
- Intuitive telephone operation provides clear two-way communication and requires little or no training for staff members
- Redundant circuitry allows for call processing even in the event of audio failure
- Direct interface with PBX for call routing
- Free Topology Wiring allows flexible cabling schemes.

Tech Works™



"Making Specialized Communication Easy"

A Division of: **United Communication Technology, Inc.**
22349 La Palma Ave., Suite #107, Yorba Linda, CA 92887

Direct Line: **714-694-1040** Fax: **714-694-1041** Toll Free: **1-800-813-1080**

Web site **www.tech4people.com**

System Design Layout and Connections -

Assisted Living

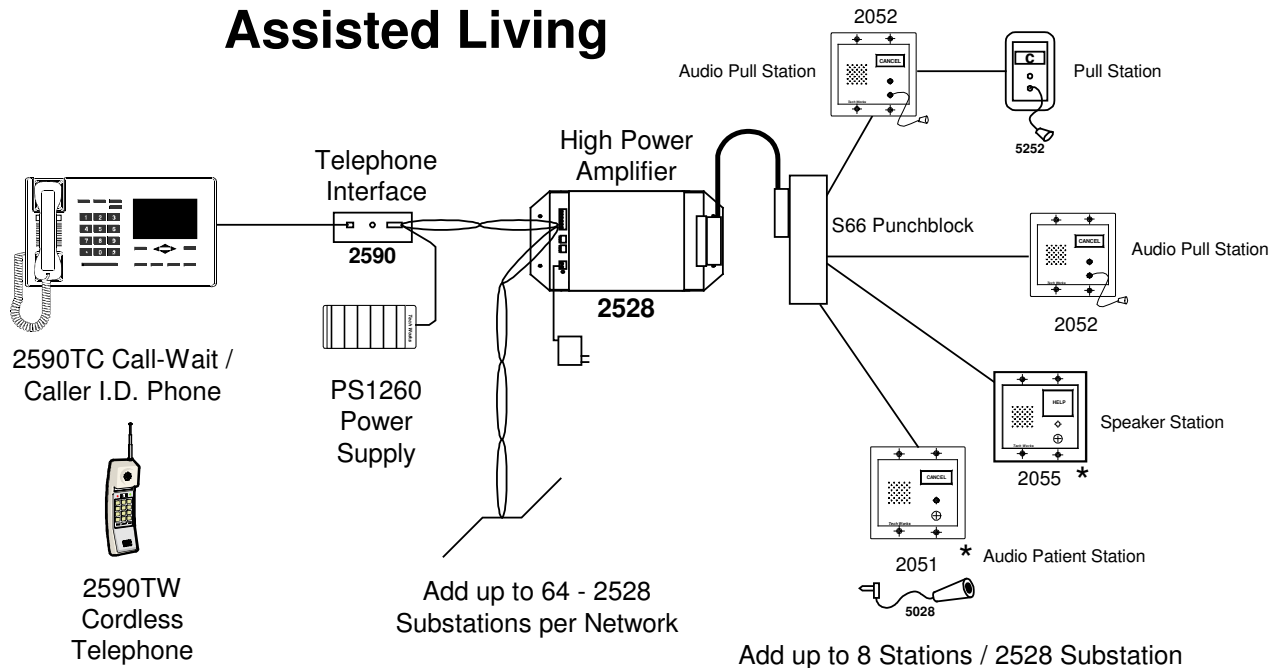

Components –

<u>Qty</u>	<u>Part #</u>	<u>Description</u>
40ea	2052	Pull Station w/Audio – One per bed
40ea	5252	Pull Station – One per bathroom
5ea	2528	Intercom Amplifier – 8 stations per amp
1ea	2590	Telephone Interface – One per Network
1ea	2590TC	Caller ID Telephone Console – Hardwired at the Nurse Station
1ea	2590TW	Cordless Caller ID Telephone – One per mobile staff member
1ea	PS1260	Power Supply – One per network
8000ft	20/3 Pair	Passive station wire
2000ft	18/3 Pair	Network wire

* Please note 2051 and 2055 are optional call stations

Tech Works Voice-Call allows staff to attend to various duties and still maintain direct contact with residents at all times with an audio station at the bedside and a pull station in the bathroom. This is ideal for assisted living and long - term care facilities with limited staff. With the addition of an optional PC, reports can be run to track staff efficiency and monitor resident call activity.