



Application – Patient Arrival and Tracking **Tech Works Solution - Light-Call**

General Description -

In today's fast paced Out Patient Medical Delivery Offices keeping track of patients is a never ending challenge. Tech Works offers simple to use low cost solutions to assist in letting staff know that they have a patient waiting and when combined with our Room Status and Doctor Follow product we let staff know where the patient is and which patient is "Next".

There are two basic types of Patient Arrival notification. In Medical Office type operations the staff needs to let other staff know that a patient is waiting to see a provider and where to find the patient. In the Typical Counseling Office the patient is asked to let the provider know that they have arrived and are waiting to be seen. We have solutions for both applications and the ability to provide others upon request.

Basic system components:

Product	Purpose or Function
5210-PA	4 Button Light Signalling Station
5260-LC	16 Button Light Signalling Station
5200-PA	8 Exam Room Annunciator with Patient Arrival Buttons
5250-LCS	Input Output Control Module
5221-CK	Check In Button
5234-*	Wall Mount Annunciator Light

Benefits of using Tech Works –

In the Medical Office application the Receptionist is typically given a set of buttons which they push to let staff and providers know that patients are waiting. This can be a 4, 8, or 16 button unit depending on size of office and type of notification required.

In the Counseling Office a 4 or 16 button panel is placed in the lobby with the names of the providers next to each button. Upon arrival the patient is instructed to press the button to light the light letting their provider know they are present.

Annunciation and control for staff and providers can be with a light or a light and a tone located at the most convenient place available. An associated button can be provided so the provider can remotely turn off or change the status of the light if desired.

The Tech Works solution is simple to install, cost effective, and easy to use.

Tech Works™



"Making Specialized Communication Easy"

A Division of: ***United Communication Technology, Inc.***
22349 La Palma Ave. Suite 107 Yorba Linda, CA 92887

Direct Line: **714-694-1040** Fax: **714-694-1041** Toll Free: **1-800-813-1080**

Web site **www.tech4people.com**

System Design Layout and Connections -

MOB WITH PATIENT ARRIVAL

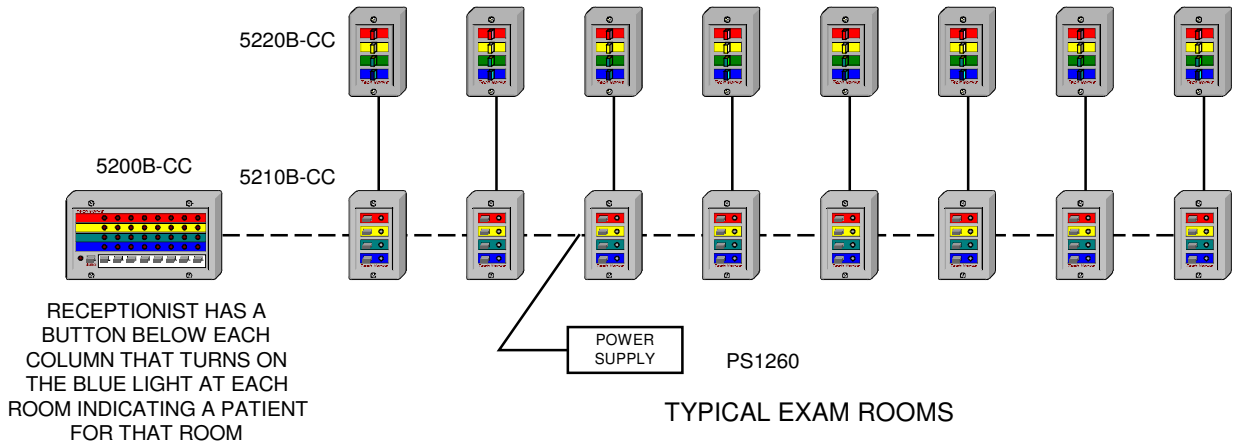

DOCTOR MOB PATIENT ARRIVAL SYSTEM

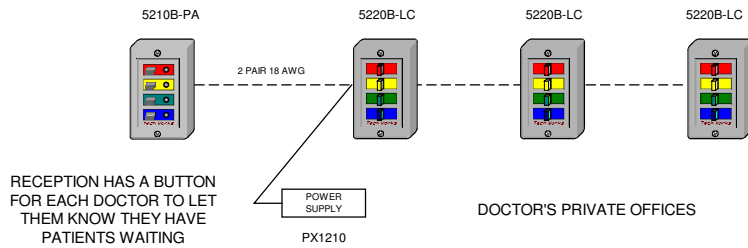

COUNSELING OFFICE PATIENT ARRIVAL

