



Tech Works™

"Making Specialized Communication Easy"



Light-Call™ Operations and Installation Manual for 5XXX SERIES

LIGHT SIGNALING SYSTEM

Tech Works Light Signaling Systems are microprocessor based communication products providing many push buttons and lights over simple twisted pair network wiring. Each system includes a combination of Stations with color-coded lights (red, yellow, green, and blue) and buttons to allow staff to communicate the status of exam rooms, waiting rooms, operating rooms, number of patients waiting, staff locations, emergencies, or many other statistics on people or facilities. One system may consist of a basic Intelligent Substation having four buttons and four lights, an Intelligent Corridor Light having four lights, and a Master Station capable of displaying up to eight Substations. Any Substation status change is reflected in the Masters lights and annunciated by a tone. All Substations have two sets of dipswitches which allow addressing of each unit. One set of dipswitches assigns a Substation to a Master and the second set selects the column of lights on the Master to represent the Substation. Any Masters, Substations, or Corridor Lights with the same address setting are totally interactive. The latest in "Distributed Microprocessor Technology" is implemented with a moisture and electrostatic resistant user interface to provide for reliable yet friendly operation. Two twisted pair network wiring reduces the cost of installation making *Tech Works Light Signaling Systems* easy to install and easy to maintain.

BENEFITS

- 256 Addressable Stations on
Two Twisted Pair Wire
- Any Masters with the Same Address Display the Same Substations
 - Any Substations/Corridor Lights with the Same Address is Totally Interactive
 - Any Station can be Added or Removed with Power On

Design Information

12 VDC Operation 5 Amp Max Load
(See Individual Data Sheets to Calculate Loads)

Master 4-Gang Electrical Box Rough-in
Substations 1-Gang Electrical Box Rough-in
Network Wiring – Category 3 or better
Two Twisted Pairs

A Division of: **United Communication Technology, Inc.**
22349 La Palma Ave, Suite 107. Yorba Linda, CA 92887
Direct Line: **714-694-1040** Fax: **714-694-1041** Toll Free: **1-800-813-1080**
Web site **www.tech4people.com**

Tech Works “Light-Call” Visual Communication Firmware Selection

How to determine the system functionality by picking the right firmware.

The hardware in this product is interchangeable
So the functions are in the Firmware

Smart Substations – (Tone Optional)



5210B

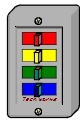

5220B



5230

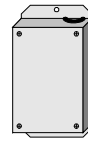

5250

Hardware suffixes that are common among various Smart Substations:

“S” – “Screw Terminals”

“T” – “Tone”

Master Stations – (Tone Standard but can be disabled)

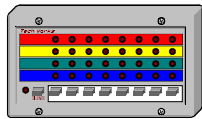

5200B

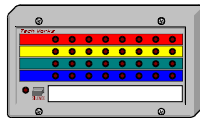

5201B

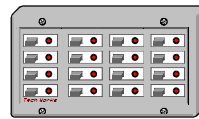

5260

The firmware that determines the functions -
Available Firmware Options:

“CC” – “Clinic-Call”

“DC” – “Duress-Call”

“LC” – “Light-Call”

“PA” - “Patient Arrival”

“ZL” – “Zone Light”

“CC” – “Clinic-Call” – Application -

This is our multifunction software for outpatient medical office applications. Clinic-Call was design specifically for “Room Status” communication to indicate What is going on in each exam room and where staff is and if they need assistance.

Colors are typically used to indicate a staff member or function. The software allows a single button to change the status of a light by how many times it is pushed. Each device with this suffix features a status light that has four different functions; “*Steady*”, “*Slow Flash*”, “*Fast Flash*”, and “*Off*”. Either the push of a button or the monitoring of “*Next Patient*” by a “*Doctor Follow*” Master controls each Light Status. In this way a color such as Yellow can indicate that a Patient is in a room waiting for Doctor Yellow if the light is On. When the Doctor enters and presses that button it changes to “*Fast Flashing*” indicating to staff that he or she is with the patient. When they are done they can press the button turning the light “*Off*” to indicate that the room is available or press another color to let another staff member know that they are needed in this room.

When CC is installed on a Substation –

Available on Models: 5210, 5220

Standard “CC” –

Each Substation has a “S” – “Software” option switch.

When the “S” switch is “Down” the buttons function as:

- a) First press – Solid Light
- b) Second press –Fast Flash Light
- c) Third press – Extinguish Light

When the “S” switch is “Up” the top button (Red) functions as:

- a) First press – Fast Flashing Light
- b) Second press – Extinguish Light

All other buttons function (Yellow, Green, and White) function as:

- d) First press – Solid Light
- e) Second press –Fast Flash Light
- f) Third press – Extinguish Light

The function of the top Light / Button depends on a dipswitch setting. When the substation dipswitch is set to the “Down” position all buttons function the same. With the dipswitch “Up”, the top button sends a “*Fast Flash*” on the first push which is used to summon Help to that room. A second push turns the Top Light “*Off*”.

Special Order “CC” Substation Options –

“CCR” - Some wanted it backwards so we *Reversed* it:

- a) First press – Fast Flash Light
- b) Second press – Solid Light
- c) Third press – Extinguish Light

“CCE” – And then some wanted it *Expanded* so the “Slow Flash” function is a button push:

- a) First press – Solid Light
- b) Second press – Slow Flash Light
- c) Third press – Fast Flash Light
- d) Fourth press – Extinguish Light

“PT” – “Patient Timer” –

This is an option only on the 5210 and effects the function of the bottom button only. All other buttons and dipswitches function as a standard Clinic-Call substation described above. Pressing the bottom button allows a count down timer to tell staff when a period of time has past. Originally this was designed for Ophthalmology clinics where the provider would put dilation drops in a patient’s eyes and when the timer expires, a flashing message is sent to the annunciator indicating that the patient is ready for examination. Many other applications have been discovered where a count down timer is required. This feature is on the bottom button and has a corresponding “*Slow Flash*” while it counts down. The count down period is 5 minutes for each push of the button so if you want to count down for 10 minutes, you push the button twice. At the end of the count down period a “*Fast Flash*” message is displayed and sent to the network. To cancel the timer and stop the “*Slow Flashing*” simply hold down the corresponding button and the light will change to “*Off*”.

When CC is installed on a Master Station –

Available on Models: 5200, 5201

The 5200 have a row of buttons across the bottom, one below each column. Pressing this button will clear all pending calls from that substation address. Both the 5200 and the 5201 have a “*Silence*” button, which stops the tone on that unit only.

Standard “CC” - In a Master Station - Clinic-Call software is our “Quiet” product. The only tone that sounds is associated with the top or “Red” row of lights and is a repeating tone when a top row light is “Fast Flashing”. Each column of lights represents an Exam Room Status by displaying the Red, Yellow, Green, and White lights from each room.

Special Order “CC” Master Options –

“DF” – “Doctor Follow” –

These Master Stations monitor the sequence of button pushes in a horizontal row. Each doctor is assigned a color, the Master indicates to the doctor which patient is to be seen next. For example, if 3 yellow lights are on in a row that indicates there are 3 patients in 3 different rooms for Doctor “Yellow”. The first one to have been turned on is changed to a “*Slow Flash*” to indicate that is the “Next” patient for Doctor “Yellow”. When that yellow light is turned “Off” the “Next” yellow light to have been push will start slow flashing.

Pressing the corresponding button on the exam room status station 5210 activates these lights on the Master. If it is desirable to change the priority level of an exam room, or which one is next, simply push the corresponding exam room status button twice within 5 seconds (double push) and that room will become the next patient for that color. By double pressing any button that station of that color will automatically start slow flashing or become “Next”. All other sequencing remains unchanged. Only the station that is double pressed moves to the top of the queue

“DDF” – “Dual Doctor Follow” –

This product is the same as the Doctor Follow Master, but designed for clinics where a group of providers is assigned to a group of only 4 exam rooms. The Master is split in half so that the first or left most four columns keep track of who is next in one of the first four rooms and the second or right most four columns keeps track of who is next in the last four rooms. This allows full tracking of more groups while employing less Masters.

Up to 16 Groups of 4 Exam Rooms can be tracked at one time on a single network.

“EDF” – “Expanded Doctor Follow” –

Expanded Doctor Follow is for the clinic where a group of providers covers more than 8 exam rooms. With this software the “Next” feature covers two Masters or sixteen columns representing sixteen exam rooms. The first Master in address sequence tracks the eight columns it displays plus the next eight addresses. This means that Master 3 will track the 8 rooms on it plus the “Next” rooms of Master 4 for a total of sixteen rooms.

Up to 4 Groups of 16 Exam Rooms can be tracked at one time on a single network.

“DC” – “Duress-Call” – Application -

This is our Emergency Call software designed for applications such as cash cages, mental health counselors, or courtrooms where a stressful situation requires a silent alarm call for assistance in dealing with people that are out of control or in great danger. The key to this software is that there is always an intelligent Substation that originates a call from a button push or other contact closure and an intelligent Master station that responds to the call.

For example in a Courtroom the Judge, Clerk, and Bailiff will all have a hidden button with a call assurance light. If something goes wrong anyone or all of them can push their button. No matter how many times the button is pushed the light on the Button and all Substations and Masters associated with that button keep flashing. When the Master in the Marshall’s Office starts flashing it also starts beeping. By pressing a button associated with the “*Flashing Light*” the Marshal changes the light from “*Flashing*” to “*On Steady*” and silences the beeping tone. This also changes the other associated lights on all Substations and the Button that originated the call to “*On Steady*”. Once the problem is addressed and the Marshalls are sure that danger is passed they can turn out the light by pressing the Button that originated the call.

The same sequence of operation applies to other applications such as mental health counselors, cash cages, or any time someone might need to secretly summon help.

When DC is installed on a Substation –

Available on Models: 5220, 5230, 5250

A contact closure, such as a 5131 Hold Up Button, connected to the intelligent Substation such as a 5220B-DCS, would place a “*Fast Flashing*” call to a Master station, such as a 5260-DC. No matter how many times the hold up button is pushed the light on the 5131 Button and the 5220B-DCS and the 5260-DC all keep flashing. The light can only be turned “*Off*” after it has been “*Acknowledged*” by a Master. Once a Master has changed a light to “*On Steady*” pressing the button which originated the call will turn the light “*Off*”.

When DC is installed on a Master Station –

Available on Models: 5200, 5201, 5210 (Mini Master, All White Faceplate), 5260

The Masters have a tone generator included, which sounds a repeating tone as long as any light is “*Fast Flashing*”. By pressing the button on the Master next to the flashing light, the light will change to “*Steady*” and will silence the tone. The corresponding lights on the Substation and the Button that originated the call will also change to “*Steady*” indicating that someone has “*Acknowledged*” the call for help and is on the way.

Once the situation is resolved and the crisis over, the originating Button is pressed changing all lights associated with this call to “*Off*”.

“LC” – “Light-Call” – Application -

This is our flagship product, which is a simple Light “On” Light “Off” Visual Only communication system designed to be a simple cost effective nurse call system for nursing homes, small hospitals, and day surgery units. This product is also used as a Doctor Register or any other application where simple visual communication is required. When coupled to the 5400 it can be used to activate other systems such as pocket pagers by simply pressing a button.

When LC is installed on a Substation –

Available on Models: 5210, 5220, 5230, 5250, 5260

Standard “LC” –

Light Call products are normally open momentary contact inputs by default.

When order on a 5210 (5210-LC) only the top button or Red is effected by the “S” dipswitch.

Each Substation has a “S” – “Software” option switch.

When the “S” switch is “Down” all buttons function as:

- a) First press – Solid Light
- b) Second press – Extinguish Light

When the “S” switch is “Up” the top (Red) button functions as:

- a) First press – Fast Flashing Light
- b) Second press – Extinguish Light

All other buttons (Yellow, Green, and White) function as:

- a) First press – Solid Light
- b) Second press – Extinguish Light

When order on a 5220, 5230, 5250, or 5260 all buttons are effected by the “S” dipswitch.

Each Substation has a “S” – “Software” option switch.

When the “S” switch is “Down” all buttons function as:

- a) First press – Solid Light
- b) Second press – Extinguish Light

When the “S” switch is “Up” all buttons function as:

- a) First press – Fast Flashing Light
- b) Second press – Extinguish Light

Special Order “LC” Options –

“LCSMK” – This is for the guys that do nursing homes and want to monitor a ***Smoke Detector***:

Available on Models: 5230, 5250

Input #1 – Maintained contact can be set for NO or NC and sends a Fast Flash (Smoke Detector by others).

Each Substation has a “S” – “Software” option switch which effects the Input #1:

When the “S” switch is “Down” the buttons function as Normally Open:

- a) Switch transition from “Open” to “Closed” – Fast Flashing Light
- b) Switch transition from “Closed” to “Open” – Extinguish Light

When the “S” switch is “Up” the buttons function as Normally Closed:

- a) Switch transition from “Closed” to “Open” – Fast Flashing Light
- b) Switch transition from “Open” to “Closed” – Extinguish Light

Input #2 – Momentary contact sends a “Fast Flash” - Normally used for the Restroom Pull such as the Tech Works 5252.

- a) First press – Fast Flash
- b) Second press – Extinguish Light

Input #3 & 4 – Momentary contact sends a Steady Lamp - Normally used for the Bed Station such as the Tech Works 5251 and or Nurse “Presence” with a 5221.

- a) First press – Solid Light
- b) Second press – Extinguish Light

“LCBRS” – This is a ***Broadcast Substation*** used to send the same information to ALL Masters. It ignores the “Master” Address and sends the information to all Masters on the “Column” set by the dipswitches. This is used to let multiple Nurses Stations know that a pull station is activated in a common public restroom and other similar applications where multiple areas need the same information. Function is Standard Light Call.

Available on Models: 5210, 5250

“MC” – “Maintained Closure” – Application –

Some of our products have been designed to monitor “Maintained Closures” such as smoke detectors or door contacts. When this feature is available the dipswitch allows the installer to select monitoring of normally open or normally closed contacts.

Available on Models: 5230, 5250

Each Substation has a “S” – “Software” option switch.

When the “S” switch is “Down” the buttons function as Normally Open:

- a) Switch transition from “Open” to “Closed” – Fast Flashing Light
- b) Switch transition from “Closed” to “Open” – Extinguish Light

When the “S” switch is “Up” the buttons function as Normally Closed:

- a) Switch transition from “Closed” to “Open” – Fast Flashing Light
- b) Switch transition from “Open” to “Closed” – Extinguish Light

When LC is installed on a Master Station –

Available on Models: 5200, 5201

The 5200 have a row of buttons across the bottom, one below each column. Pressing this button will clear all pending calls from that substation address. Both the 5200 and the 5201 have a “Silence” button, which stops the tone on that unit only.

Standard “LC” - When a Light-Call Master is used an audible signal is generated as well as a visual indicator of all calls. Any “Fast Flashing” light has an associated repeating tone and any “Steady” light has a single tone followed by a “Reminder” tone every 20 seconds.

“PA” - “Patient Arrival” – Applications

Patient arrival is done in one of two ways. As a stand-alone system in counseling offices or as a Master option used in medical clinics.

When used in Psychologist Offices a 5210 or 5260 is placed in the waiting room and each button is labeled with a provider’s name. Typically there is no Receptionist. A passive button such as the 5221-CK “Check-In” button is placed in each provider’s counseling room. When a Patient arrives they press the button next to their providers name which starts the light next to their name and on the corresponding “*Check-In*” button in their room “*Fast Flashing*”. The provider then knows their next patient is waiting and they have the option of pressing the “*Check-In*” button and turning off the light or waiting until they go to the lobby and pressing the corresponding button that originated the light to turn it “*Off*”.

When used in a Medical Clinic the receptionist has a Master Panel with buttons associated with each exam room. When a patient arrives the receptionist presses the button assigning that patient to an available room. This would then light the associated light on other annunciators and the room stations indicating that a patient is in the waiting area and needs to be moved to this room. Typical use is to alert the file staff to pull the chart and take the patient to the room. Once the patient has been put in the room the light is turned off and a colored button for a provider is pushed indicating a patient is in a room waiting for that provider.

When PA is installed on a Substation –

Available on Models: 5210 (5210-PA with all White Face Plate),
5210C (5210C-PA with Colored Face Plate), 5250, 5260

Standard “PA” –

Each Substation has an “S” – “Software” option switch.

When the “S” switch is “Down” the buttons function as:

- a) First press – Solid Light
- b) Second press – Extinguish Light

When the “S” switch is “Up” the buttons function as:

- a) First press – Fast Flashing Light
- b) Second press – Extinguish Light

Special Options –

“CCP” –Some wanted a timer where each button functions as follows:

- a) First press – Solid Light
- b) If after 5 minutes the light has not been extinguished it will change to Fast Flashing Light and send the associated network message.
- c) Second press – Extinguish Light

When PA is installed on a Master Station –

Available on Models: 5200

The 5200 Master has a button below each column of lights. When ordered with the Patient Arrival option this button activates the bottom light in each column. The corresponding bottom light on any Substation such as a 5210 or 5220 is controlled.

Standard “PA” –

- a) First press – Solid Light
- b) Second press – Extinguish Light

“ZL” – “Zone Light” – Application

Available on Models: 5220

Intended to provide a light indication of any Substation call associated with a Master or 2 Masters. Any call by color on a Master is indicated by the corresponding color. The light status is the highest status at any time. If a “*Steady*” Yellow call is present on a Master and no other call is on of the same color, the 5220 -ZL will have a “*Steady*” Yellow light. If a “*Fast Flashing*” Yellow light comes on the same Master, the Zone Light will change to “*Fast Flashing*” on the 5220-ZL. If the “*Fast Flashing*” Yellow light goes Off and the “*Steady*” Yellow light is still on, the light on the 5220 -ZL will return to “*Steady*”. If the “S” option switch on the 5220 is up it will represent 2 Masters starting with the address corresponding to it’s Master address setting plus the next Master address. If the “S” is down the 5220 -ZL will only represent the Master matching its address. The Substation or column address is ignored on this device.

Other suffixes that are common among various Substations:

“S” – “Screw Terminals” –

On selected Substations optional screw terminals are available to connect passive devices. These terminals have labeled connections for “Switches” and “LEDs” to connect wires to things such as passive dome lights, patient stations, pull stations, and hold up buttons.

“T” – “Tone” –

On Master Stations a tone is included. On substations it is an option to add tone. When this option is included on intelligent stations the tone will be repeating on “*Fast Flashing*” lights and a single tone on “*Steady*” lights. No tone silence is available. On passive stations the tone simply does whatever the light does. This is not recommended for passive stations intended for “*Steady*” lights.

Network Wiring

Tech Works Light-Call™ products are distributed microprocessor systems operating on two twisted pair wiring. The first pair is 12 VDC power in a parallel connection plan. The second pair is RS485 terminated bus topology, operating at 39K baud in a parallel connection plan. Because this is a distributed processor system, each intelligent device contains a micro controller, so there is "NO Central Processor". Each device is totally self-contained and can be used as a stand alone or in combination with any other intelligent device.

Four (4) screw terminals are provided on each intelligent device for connection to the network. The screws are labeled "+" and "-" for DC Power and "T" and "R" for Transmit/Receive Data connections. On each station in the middle of the system there should be two wires attached to each screw and on the end only one wire to each screw. If there are more than two or none at all, the system will not operate properly.

Note: Be sure to securely tighten screws so that wires will not come loose.

U.L. Torque Spec: 3.5 lb. - in.

The system is designed to operate on unshielded twisted pair cable from 24 to 18 AWG. The twist of the cable is critical to the proper communication of data on the network to avoid noise interference. Any standard voice grade twist should provide adequate noise cancellation under normal operating conditions. However, if you are installing a system in a high electro magnetic radiation environment you should consider data grade twist for all cables.

All wiring is NEC Class 2.

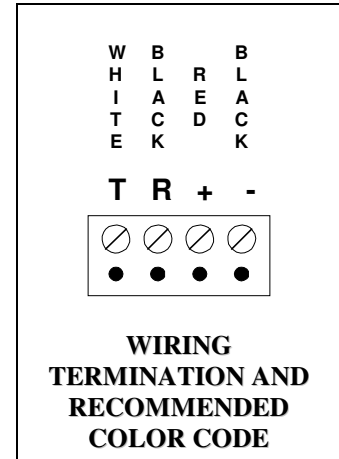

Due to the implementation of innovative data noise canceling circuits in all Tech Works RS485 microprocessor products, the data and power can now be run in any direction upto a total wire length of 3000 feet.

The last station on each end of all wire runs must employ a terminating resistor to make the network operate correctly. The terminator is built into each station and selected by turning "ON" the "T" dipswitch. If a terminator is placed in the middle, data will not flow to all devices in the system causing irregular operation.

As with any RS485 communication system grounding is critical to the proper operation and life expectancy of the system. All *Tech Works* power supplies employ a floating ground designed to isolate the data communication from interference and destructive electro static discharges. The use of multiple power supplies on the same network will cause different floating ground references (ground loops) which may cause noise and destruction of the intelligent devices.

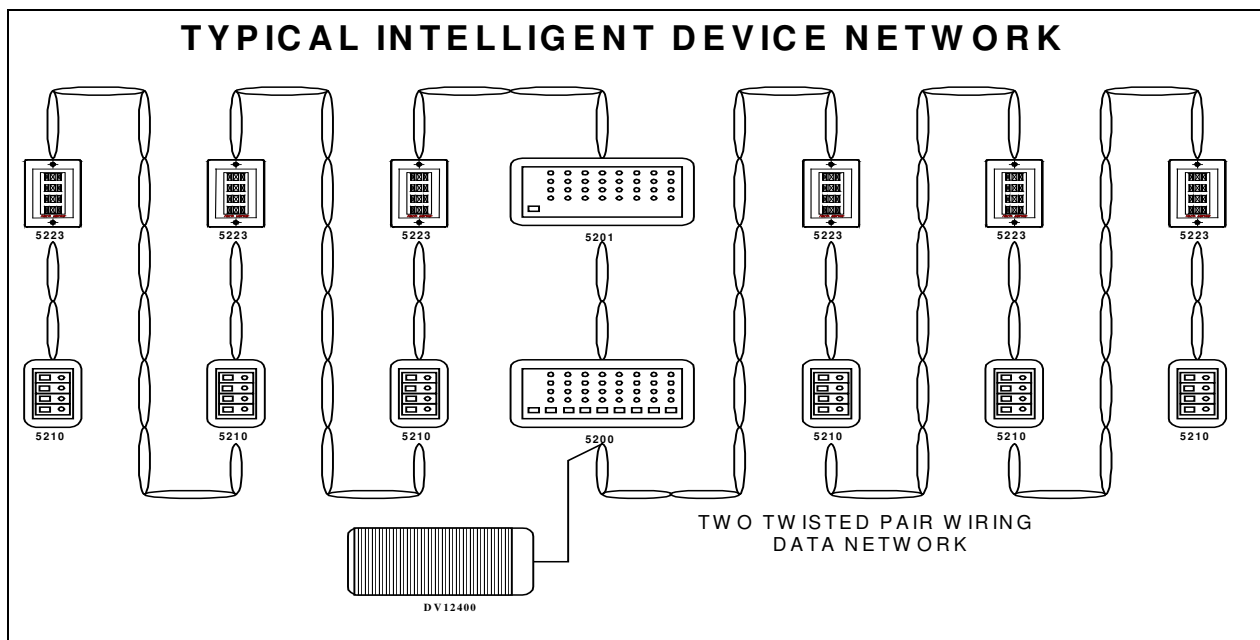

Power and Grounding

The power consumption of each component is listed on the individual data sheets. Although the system is designed to operate on a 12 Volt DC power source, the actual station operating voltage is only 9 volts or greater. Under normal operation this design allows minor power fluctuations to go unnoticed. Because each device has a built-in regulator, filter, and surge suppressor the supply voltage can rise as high as 24-48 volts and drop to as low as 9 volts before any loss of service occurs. We recommend a constant 12 to 16 volts to maintain system operation over long cable runs and overload conditions.

To assure that you select the right power supply, simply add the current consumption of each device designed into each system. Master Stations and Annunciators require 164 mA to light all LED's at the same time. Although this is unlikely, it is recommended that you design for this "worst case" operation. This would mean that a system with two Masters and two Annunciators would require 656 mA of current just for the Masters. Each model **5210** Intelligent Substation requires 60 mA and each model **5223** Intelligent Dome Light requires 240 mA. Thus, for a system with 12 patient rooms each having a model **5210** and a **5223** the Substation current requirement would be 3.6 Amps. Add to this the current required for the Masters and Annunciators and this system would require a power supply capable of delivering 12 Volts at 5.0 Amps for full operation.

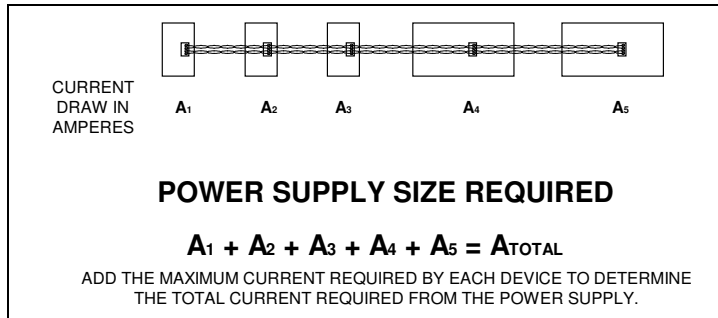

Wire size is very critical to the proper operation of a system. Too large a wire and your price will be too high and you might not get the job. Too small a wire and the system may fail to turn on when you power it up. If you have Stations that come on but then go off, or seem to *flash* on and off and nothing else, this is an indication of too small a wire. Measure the voltage at the back of the station; at least 9 volts DC must be present for the station to boot strap or start.

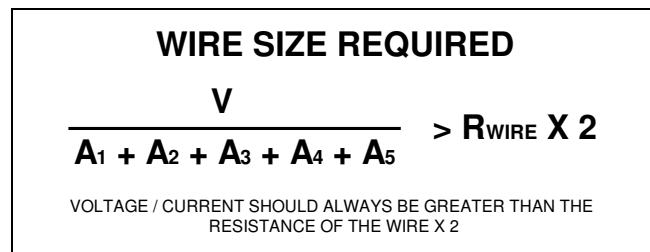

Connect the power supply as near the middle of the network loop as possible to assure the best possible power distribution. The power source for the system may be connected at any device on the network. This would cause three wires to be connected to one pair of screws in the middle of the system or two pair on the end. The power supply should be located at your convenience near an AC power outlet. To assure maximum efficiency the power source should be as close as possible to the network. Power connections are polarity sensitive so always be certain to maintain the color code and polarity on all connections.

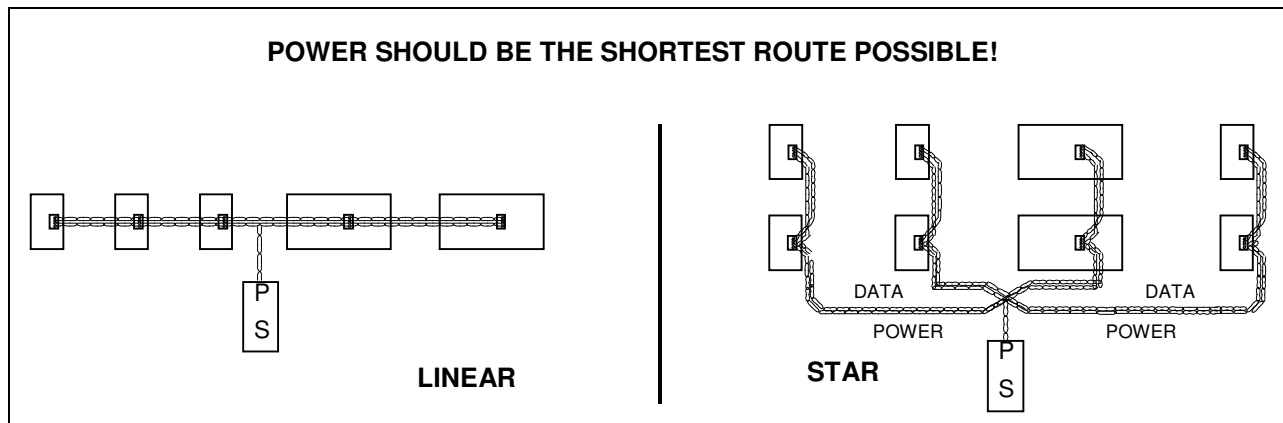

Master Station Operation

The *Tech Works* Master is a simple Eight Room Annunciator with Four Status Lights and a Remote Reset Button for each room (optional by part #). The lights reflect the status of Substations assigned to a Master. Each column of lights represents a room/Substation and shall be color-coded red, yellow, green, and white to easily identify functions or staff. An integral tone sounds to draw attention to any change of status. A silence button is provided to stop the repeating tone associated with "flashing" lights. A remote station reset button beneath each column of lights (optional), allows any room to be cleared by the Master. The Master address is set by a four-position dipswitch. Any Masters having the same address will display the same Substations. The tone can be permanently disabled via a jumper on the rear of the Annunciator.

Master Station Switch Settings

Master and Annunciator Stations are only equipped with a Master address dipswitch. The setting of the address is exactly the same procedure as the Substation setting. The "T" or terminator switch should be used if the Master is on either end of the network. Multiple Masters on the same network will only display the Substations having the same Master address as the Master Station. If multiple Masters are required to display the same information, just set the Master address the same on as many Masters or Annunciators as you need.

Notes: Optional dipswitch is not being used at this time.

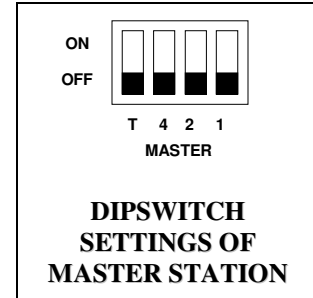

Labeling of Master/Annunciators

Some of our products have user printable faceplates for field custom labeling of devices. These faceplates consist of a clear windowed Lexan and a paper label. The paper is designed for use in a standard laser jet printer. Any CADD, word processor, or graphics program will allow the installer to create custom verbiage and print it onto the paper. A form should be created so the text will line up through the Lexan windows. We recommend several test prints on scrap paper before final printing on paper labels. If you own "Form Tools" software, a standard set of forms are available from us for use with HP printers. Additional labels and Lexan faceplates are also available. Dimension details can be obtained from our engineering department.

Once alignment is complete and labels are printed, simply place it on the Master Station bezel. The bezel comes with a recessed area for alignment of the faceplate. By placing the paper against the top edge of the recess and then pressing down over the lights and buttons, the openings and text should automatically line up. Next, repeat the process by applying the Lexan faceplate over the paper. Rub the Lexan horizontally as you apply it to the paper to remove as much air as possible, giving the maximum color transfer and clarity.

Zone Light

Upon activation of any Substation on a Master, the Zone Light will reflect the status of the highest priority Substation on that Master. If all Substations are off then the Zone Light is off. If any Substation has a *steady* light and no other Substation has a *flashing* light the Zone Light will be *steady*. If any Substation has a *flashing* light the Zone Light will be *flashing* until all *flashing* lights are off. The Intelligent Data Network Communication allows the status of Intelligent Master/Sub Annunciator Stations to be monitored with only two pair wiring. A software selection dipswitch allows the Zone Light to monitor only the Master address to which it is assigned ("S" down) (or its Master) plus the next one in sequence ("S" up).

Substation Operation

The *Tech Works* addressable Substations are a family of simple Four Button, Four Light Room Stations. The four buttons/lights shall be color-coded red, yellow, green, and white to easily identify functions or staff. The different functions of these buttons depend on the software installed in each unit. Each family of products has different software installed which provides a different set of features.

In the *Clinic-Call*™ product the first push of each button lights a "steady" corresponding lamp. A second push changes the lamp to "flashing". A third push extinguishes the lamp.

In the *Light-Call*™ product the first push of each button lights a "steady" or "flashing" corresponding lamp depending on the position of the "S" dipswitch. A second push extinguishes the lamp.

The Intelligent Data Network Communication allows the status of these buttons and lights to be sent to Intelligent Master/Sub Annunciator Stations.

Substation Switch Settings

Each Substation is equipped with two sets of four-position dip-switches. This is the only installer programming required for installation. The first set of switches selects the Master or group of Masters on which this Substation will be displayed. The second set of dipswitches selects the column of lights on the Master to represent this Substation. Any two Substations with the same address will be totally interactive. This means that the push of a button on one Substation will light its light as well as the light on the other Substation with the same address.

On the first (or Master) dipswitch, the left most switch labeled "T" is a built-in terminating resistor. This is provided to tell the network where the first and last devices in the system are located. On the first and last Station in a system the "T" switch must be set to the up (or on) position for proper network communication. All other "T" switches in the system must be set to the down (or off) position. The last switch to the right is labeled "1". This represents Master number 1 or 0. If the switch is down (or off) the switch represents a 0. If the switch is up (or on) the switch represents a 1. The third switch is labeled "2." This represents a 0 in the down position or a 2 in the up position. The second switch from the left is labeled "4."

This represents a 0 in the down position and a 4 in the up position. By adding the value of the switches in the up (or on) position the address of the Master is selected. For example: all switches down are Master 0; switches 1, 2, and 4 all up are Master 7; switch 1 and 4 up is Master 5; etc.

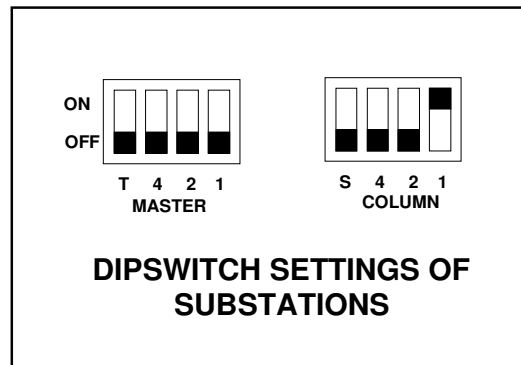

The second set of dipswitches selects the column of lights on a Master to represent this Substation. As with the Master selection the number values are additive. The first column to the left on a Master is column 0 and is addressed by all switches in the down (or off) position. The last or right most columns of lights on a Master is column seven and is addressed by all dipswitches being in the up position. Column six would be addressed by switch four and two being in the up position. The left most switch in the column group is labeled "S" for software. The standard Substations are shipped with two software variations installed. The "S" down position provides the default operation which is the first push of each button lights a *steady* lamp and is accompanied by a single annunciation tone at the Master and the second push of a button changes the lamp to *flashing* and is accompanied by a repeating tone at the Master. The "S" up position provides the second software variation which is normally the top most button lights a *flashing* lamp and is accompanied by a repeating tone at the Master upon the first push of the button. All other buttons remain first push *steady* lamp, second push *flashing*. This software option may be changed to meet special applications. If a job shop or special software has been ordered, documentation will be included with the product indicating the second function of the "S" switch.

SUBSTATIONS ASSIGNED TO MASTER "O"

SUBSTATIONS ASSIGNED TO MASTER "1"

MASTER 1 OF 8 (0-7)		COLUMN 1 OF 8 (0-7)		MASTER 1 OF 8 (0-7)		COLUMN 1 OF 8 (0-7)	
1 (BINARY 0)	ON OFF			1 (BINARY 1)	ON OFF		
		T 4 2 1 MASTER	S 4 2 1 COLUMN			T 4 2 1 MASTER	S 4 2 1 COLUMN
1 (BINARY 0)	ON OFF			2 (BINARY 1)	ON OFF		
		T 4 2 1 MASTER	S 4 2 1 COLUMN			T 4 2 1 MASTER	S 4 2 1 COLUMN
1 (BINARY 0)	ON OFF			3 (BINARY 2)	ON OFF		
		T 4 2 1 MASTER	S 4 2 1 COLUMN			T 4 2 1 MASTER	S 4 2 1 COLUMN
1 (BINARY 0)	ON OFF			4 (BINARY 3)	ON OFF		
		T 4 2 1 MASTER	S 4 2 1 COLUMN			T 4 2 1 MASTER	S 4 2 1 COLUMN
1 (BINARY 0)	ON OFF			5 (BINARY 4)	ON OFF		
		T 4 2 1 MASTER	S 4 2 1 COLUMN			T 4 2 1 MASTER	S 4 2 1 COLUMN
1 (BINARY 0)	ON OFF			6 (BINARY 5)	ON OFF		
		T 4 2 1 MASTER	S 4 2 1 COLUMN			T 4 2 1 MASTER	S 4 2 1 COLUMN
1 (BINARY 0)	ON OFF			7 (BINARY 6)	ON OFF		
		T 4 2 1 MASTER	S 4 2 1 COLUMN			T 4 2 1 MASTER	S 4 2 1 COLUMN
1 (BINARY 0)	ON OFF			8 (BINARY 7)	ON OFF		
		T 4 2 1 MASTER	S 4 2 1 COLUMN			T 4 2 1 MASTER	S 4 2 1 COLUMN

USE "T" TO TERMINATE THE LINE

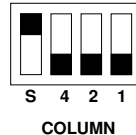

"S" IS USED TO SET SOFTWARE OPTION

Passive Device Wiring

Some Intelligent Substations have screw terminals for connection of passive devices. The terminals labeled SW are a contact closure input. The terminals labeled LED (+ -) provide 12 VDC current limited output to power external LED's (lights). The "-" terminal is a pull to ground (Common) control capable of providing 125 mA of on / off switching for external devices or control. Some passive stations are critical on switch polarity. If stations do not function, check polarity of wiring.

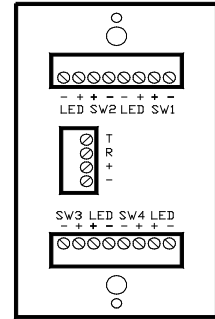

Corridor Lights are typically the largest current users. In systems with a large number of Corridor Lights it may be desirable to use multiple power supplies. The **5234** is opto-isolated for use with multiple power supplies. Whenever using more than one power supply on a system be certain to follow proper grounding and **never connect power supply outputs together**. **WARNING - THE EQUIPMENT THAT IS CONNECTED TO THIS INTERFACE IS NOT CONSIDERED TO BE PART OF THE SYSTEM CONFIGURATION UNLESS THE EQUIPMENT IN QUESTION COMPLIES WITH THE STANDARD FOR HOSPITAL SIGNALING AND NURSE CALL EQUIPMENT UL1069.**

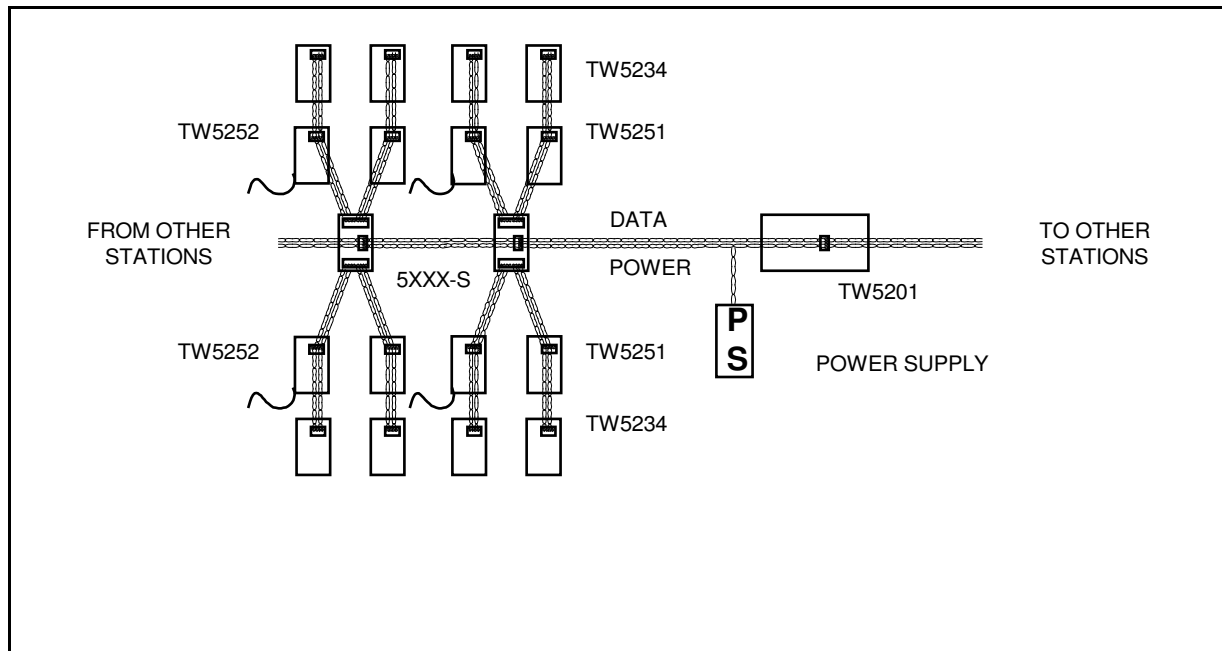

The *Tech Works 5234* is a passive Corridor Status Light for use with the **5230S** and **5260** or any other Intelligent Substation with the screw terminal ("S") option. This unit does not have data network interface components and is intended as an output signal device to be used with intelligent modules. This unit can be paralleled with other passive devices to provide a wide array of output signals and user interface buttons. Interfacing with the Intelligent Data Network allows the status of these buttons and lights to be sent to Intelligent Masters, Annunciators, and Substations. This unit is not U.L. listed at this time.

Many other passive button and light assemblies such as the **5221**, **5131**, **5251**, and the **5252** are available for use with Intelligent Substations. Most Intelligent Substations are available with an "S" suffix model indicating screw terminals for connection of passive devices. Although these are specifically designed for *Tech Works* products they are compatible with a wide variety of industry standard normally open contacts and low voltage lights. The **5221** and **5131** are not U.L. listed at this time. Please contact the factory for specific applications not listed.

Mechanical

The Master Annunciator can be flush mounted to the wall using an industry standard four-gang electrical box and a plaster ring. The plaster ring should be recessed slightly in the wall and not protrude. Using the four 1" trusshead screws provided with the Master, fasten the Master to the ring using the center holes top and bottom. When programming is completed, place the bezel on the Master and fasten using the 3/8" ovalhead screws.

The Substation can be flush mounted to the wall using an industry standard one-gang electrical box and a plaster ring. The plaster ring should be recessed slightly in the wall and not protrude. Using the 1" trusshead screws provided, fasten the Substation to the ring. When programming is completed, place the bezel over the Substation and fasten using the 3/8" ovalhead screws.