

SA-202 Stereo Audio Amplifier

The SA-202 is an attractive solution where a moderate power amplifier is required. The design gives the highest audio clarity. The frequency response characteristics are ideal for commercial requirements. The unit is protected against short circuits, overload, and other user abuses.

The SA-202 packaging is solid, unlike consumer products, and tailored to act as a companion to other Tech Works products. Several mounting options are available, Tabletop, Under Counter, and Rack. The 1U, half rack size compliments other Tech Works products for a complete single source solution. The SA-202 is designed to industry standards and is ideal in any application requiring a moderate power amplifier.

The SA-202 is easy to use. All connections are through Euro Style connectorized barrier strips. The documentation is complete. Applications utilizing other Tech Works products are fully templated.

Architects' and Engineers' Specifications

The Stereo Audio Amplifier shall be 1.75" High, 8.5" Wide, and 6" deep producing 20 watts per channel into an 8 ohm load with less than 0.1% distortion. The input shall be industry standard 0dBm at 10K ohms and all terminations shall be "Euro" style screw terminals. The power supply shall be 24 VDC universal AC source type.

The Stereo Audio Amplifier shall be Tech Works Model SA-202.

BENEFITS

- Very Versatile
- Easy to use
- High Quality Audio
- Very low distortion
- Attractive, a compliment to your design and installation
- Compact, 1U half rack
- Several mounting options
- Fully fault Protected
- Universal Power Supply

Design Information

Stereo Audio Amplifier
 Inputs, R.F. and static electricity protected
 Outputs, short circuit protected
 Frequency Response 50 Hz to 16KHz
 20-Watts RMS Sine Wave output into 8 Ohms (Balanced), Both channels full power.
 Distortion at full rated output < 0.1% T.H.D
 Input: 10K Ohms – 0dBm
 Color: Light Gray metal enclosure
 Power: 24VDC, 3.7A
 Power Supply not included
 Weight: 3 lbs.
 Dimensions: 8.5" W X 6" D X 1.75" H.



Tech Works™

"Making Specialized Communication Easy"

A Division of: **United Communication Technology, Inc.**
22349 La Palma Ave. Yorba Linda, CA 92887

Direct Line: **714-694-1040** Fax: **714-694-1041** Toll Free: **1-800-813-1080**

Web site **www.tech4people.com**

SA-202 Connection to IC-52-ENH

The SA-202 Stereo Amplifier was specifically designed for use with the IC-52 Intercom amplifier. This does not mean it can't be used in other applications but the following is the installation for its intended use.

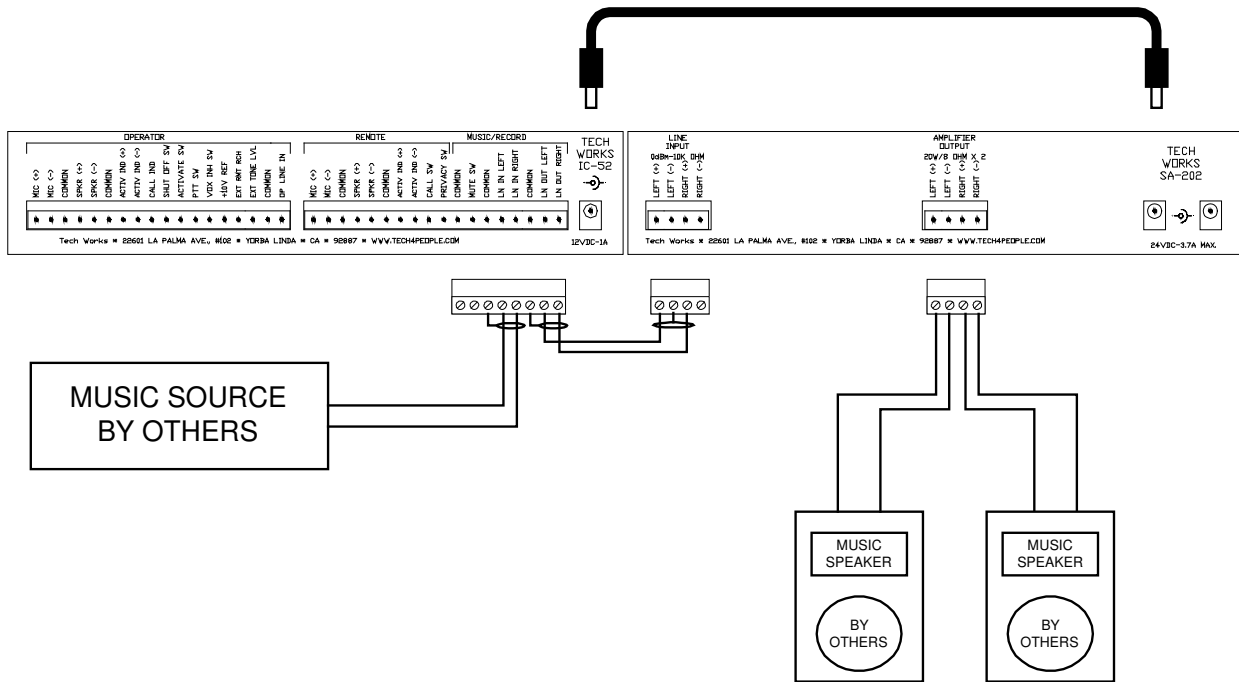

Because the IC-52 includes a power supply which is larger than it's needs the power supply for the IC-52 is capable of powering both the IC-52 and the SA-202. For this reason a 12 inch power jumper cord is included with the SA-202. The power supply is then plugged into the SA-202 and the power jumper cord is plugged from the SA-202 to the IC-52.

The Music Source is then connected to the LN IN connections on the IC-52. The LN OUT connections on the IC-52 then feed the LINE INPUTS if the SA-202. In this way the IC-52 has complete control of the music. Please review the Jumper Settings for the IC-52 Option Board in the IC-52 manual for proper configuration of muting and other functions of the IC-52. The intent is that when the IC-52 wants to carry on an open voice conversation the music is muted. And when the IC-52 is finished with the conversation the operator pushes a button labeled "Shut Off" and the music slowly ramps back up to full listening level.

If it is desired to use the SA-202 as a stand alone product the power supply is available as a separate option item.