



Application – Medical Clinic **Tech Works Solution – Clinic-Call**

General Description -

A clinic usually consists of a group of Doctors with multiple exam rooms. Efficient use of exam rooms is the key to profitability and has become the model for managed healthcare. Some clinics have several staff members supporting each doctor creating a need for simple communication in the clinic that will benefit both the doctor and the staff.

Tech Works can help. An advanced technology communication system that is simple to install can help identify exam room status so that doctors and staff can quickly locate a patient or available exam room. By maximizing exam room use, more patients can be seen in a day with less stress and confusion. The Clinic Call system is designed to be flexible to handle all of a clinic's operational communications needs.

Room Status - 4 light / 4 button patient room Substations. The four lights/buttons are color-coded red, yellow, green, and white to easily identify functions or staff.

Dr. Follow – an eight patient room Master with four colored status lights for each room allows the doctor to tell the next patient or room waiting and the staff can tell where the doctor is. Each provider is represented by a color. Software controls the *flash* rate of lights to indicate the next room that is ready for the provider. The sequence tracks the order of patients waiting based of order of arrival.

Patient Arrival / Chart up - an eight patient room Master with eight columns of four status lights and a patient arrival button for each room. Pushing the button activates the bottom light on both the column on the Master and the bottom light on the assigned Substation to communicate that a patient is waiting for a room.

Emergency Call / Lavatories – Staff Assistance and restrooms require Push for Help Buttons and Bath Pull Stations to allow Staff and Patients to call for help. By adding passive stations to a smart module these features reside on the same system as the other communication and display on the same annunciators.

Basic system components:

Product	Purpose or Function
5210CC	Substation provides 4 color-coded buttons for staff to assign room status. 1 per Exam Room.
5220B-CC, 5234, 5254	Corridor Light provides quick recognition of room status from a distance. 1 per Exam Room.
5200CC, 5200DF, 5201CC, 5201DF	Annunciator provides staff quick identification of up to eight exam rooms on a single panel 1 per 8 rooms. 1 Annunciator of appropriate type at each administrative location.

Tech Works™



"Making Specialized Communication Easy"

A Division of: **United Communication Technology, Inc.**
22349 La Palma Ave. Suite 107 Yorba Linda, CA 92887

Direct Line: **714-694-1040** Fax: **714-694-1041** Toll Free: **1-800-813-1080**

Web site **www.tech4people.com**

5/07

System Design Layout and Connections -

Tech Works CLINIC-CALL™

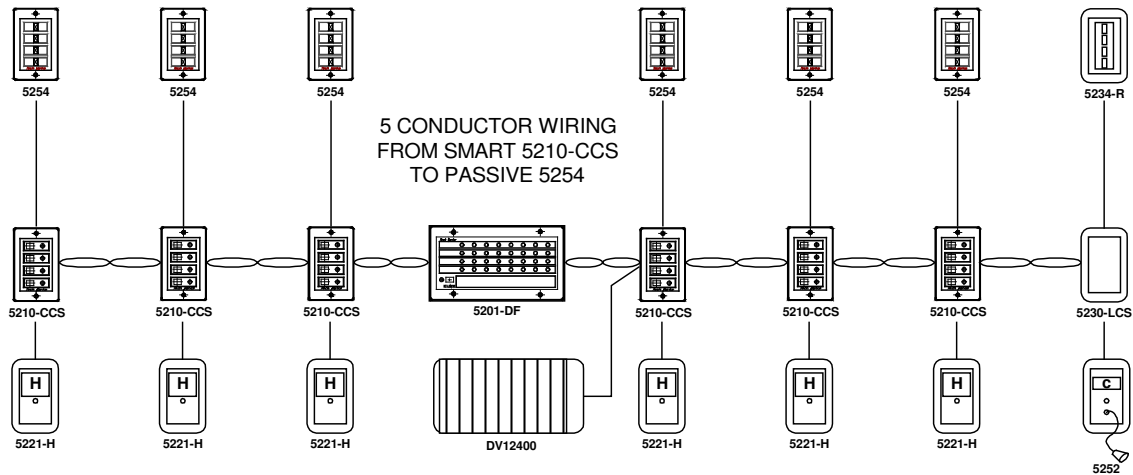

Components –

<u>Qty</u>	<u>Part #</u>	<u>Description</u>	<u>Purpose / Use</u>
6ea.	5210-CCS	Room Status Push Button Panel	One per room for System Input.
6ea.	5254	Passive Corridor Light	One per room for System Output.
6ea.	5221-H	Push for Help	One per room for Staff to call for Help.
1ea.	5201-DF	Dr. Follow Master	One per system at central reception.
1ea.	5230-LC	I/O Module	I/O processor for Lavatory pull stations.
1ea.	5234-R	Corridor Light	Passive corridor light for Lavatory.
1ea.	5252	Pull Station	Passive station for Public Restroom.
1ea.	DV12400	Power Supply	Supply based upon load calculation.
100ft.	22/2 Pair	Cable to passive stations.	
500ft.	18/2 Pair	Network Wire	

Benefits of using Tech Works – Clinic-Call™

- Distributed intelligence allows for redundant operation without an expensive central controller.
- Simple wiring allows for quick installation and expansion as practice grows.
- Requires little or no training for staff members.

Tech Works systems meet the specialized needs of Clinics with Dilation Timers built into substations and Dr. Follow systems which maximize exam room use and keep doctors moving. Tech Works is the specified standard for Kaiser Permanente and many other private clinics across the country.